

Thick Bracket (Perpendicular Machining)- Series, 10mm Slot, 1 Slot

- **Features:** Perpendicularly machined type Extruded Brackets with tabs to fit extrusions. Brackets with tabs to fit in slots of extrusions and stop rotating when tightening.

● Thick Brackets (Perpendicularly Machined)

Part Number	Perpendicularity K
DHBKTST8	0.03
DHBKTS8	0.06
DHBKTSB8	

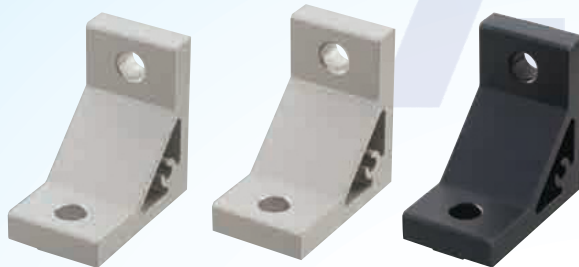

DHBKTST8
DHBKTS8
DHBKTSB8
(Black Anodize)

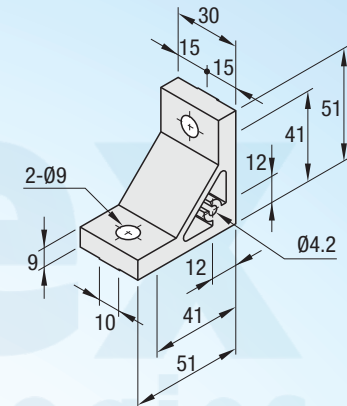

Part Number	M Material	S Surface Treatment
DHBKTST8	A6N01SS-T5	Anodize
DHBKTS8		Black Anodize
DHBKTSB8		

Part Number	Mass (g)	Applicable Screw, T Nut				Allowable Load (N)
		Screw	Quality	T Nut	Quality	
DHBKTST8	65.8	CBM8-20	2	HNNT8-8	2	HNNT8-8
DHBKTS8						
DHBKTSB8* (Black Anodize)						

Perpendicularly Machined Type has protrusions on the bracket bottom to be inserted into aluminum extrusion slots.

