

Compact Flanged Linear Bushings, Single / Double / Opposite Counterbored Hole

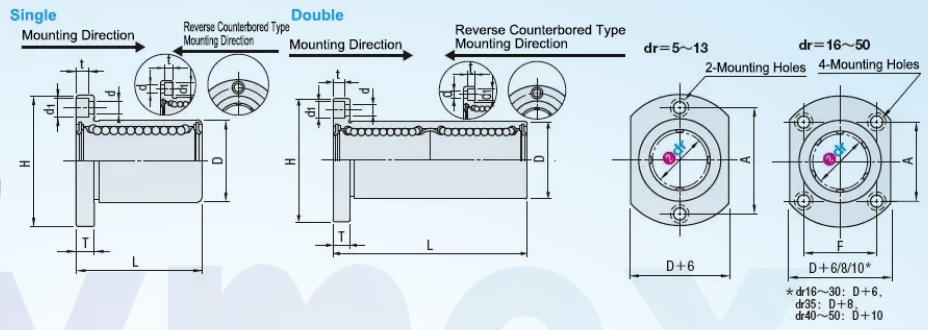

The flange part of this product is not heat treated and may have dents or scratches.

Counterbore Type	Type		Housing			Balls	Retainer	Operating Environment Temperature	Accessory: Seal ring
	Single Liner	Double Liner	M Material	H Hardness	S Surface Treatment	M Material	M Material		M Material
Reverse Counterbore Type	DE-LBHZ UU	DE-LBHZ LUU	Equivalent to SUJ2	58 HRC or more	—	Equivalent to SUJ2	Resin	-20 to 80°C	Nitrile Rubber
Standard Type	DE-LBH UU	DE-LBH LUU			Electroless Nickel Plating				

*For inner diameter 5, the retainer is black; for inner diameters 6 to 50, the retainer is yellow.

Type				Outer Diameter D Tolerance				Overall Length L			H	T	d	d _i	t	
Type	dr	Single Liner Tolerance	Double Liner Tolerance	Type	Single Liner Type No Surface Treatment	Double Liner Type No Surface Treatment	Single Liner Type With Surface Treatment	Double Liner Type With Surface Treatment	Single Liner Type	Double Liner Type						Double Liner Type
DE-LBH DE-LBHM	5		+0.003 -0.013		10 0 -0.013	0 0 -0.015	0 0 -0.015	0 0 -0.015	15	28	±0.3	25	5	3.5	6	3.3
DE-LBH DE-LBHM	6	+0.003 -0.013	+0.003 -0.013	DUU (Single Liner Type)	12	0	0	-0.015	19	35	±0.6	28				
	8				15	0	0	-0.016	24	45		32				
	10				19	0	0	-0.018	29	55		40				
	12				21	0	0	-0.018	30	57		42				
	13				23	0	0	-0.018	32	61		43				
	16				28	0	0	-0.021	37	70		48				
	20				32	0	0	-0.021	42	80		54				
25	40	0	0	-0.021	59	112	62									
30	45	0	0	-0.021	64	123	74									
DE-LBH DE-LBHM	35	+0.003 -0.016	+0.003 -0.016	DLUU (Double Liner Type)	52	0	0	-0.028	70	135	±0.6	82	10	6.6	11	6.1
	40				0	0	-0.028	80	151	96						
	50				0	0	-0.032	100	192	116		13				

Inscribed Circle Diameter dr	P.C.D	A	F	Eccentricity (mm)		Balls Number of Rows	Perpendicularity		Basic Dynamic Load Rating C (N)		Basic Static Load Rating Co (N)		Weight (g)		Double Liner Type Static Allowable Moment (N·m)
				Single Liner Type	Double Liner Type		Single Liner Type	Double Liner Type	Single Liner Type	Double Liner Type	Single Liner Type	Double Liner Type	Single Liner Type	Double Liner Type	
5	17	17		0.02	0.025	4	0.02	0.025	167	261	206	412	16	20	2
6	20	20	-	0.024	0.028		0.024	0.028	206	324	265	529	21	28	2.18
8	24	24							265	431	380	784	33	47	4.31
10	29	29							372	588	549	1100	64	90	7.24
12	32	32				412			657	598	1200	68	102	10.9	
13	33	33	22	0.03	0.03	0.03	0.03	510	813	784	1570	81	123	11.6	
16	38	31						775	1230	1180	2350	112	182	19.7	
20	43	36	24	0.03	0.04	0.03	0.04	882	1400	1370	2740	167	247	26.8	
25	51	40	32					980	1560	1570	3140	325	525	43.4	
30	60	49	35					1570	2490	2740	5490	388	645	82.8	
35	67	55	38	0.04	0.045	6	0.04	0.045	1670	2650	3140	6270	575	945	110
40	78	64	45						2160	3430	4020	8040	913	1423	147
50	98	76	62						3820	6080	7940	15900	2037	3437	397

Basic Specifications

- Type - Flange
- Outer Sleeve Material - SUJ2 Equivalent
- Motion - Linear
- Retainer Material - Plastic
- Flange Shape - Double-sided Cutting Flange
- Flange Type - Standard Flange
- Lubrication Type - Not Provided
- Types - Standard Flange
- Seal - Provided
- Style - Standard
- Accuracy - Standard Grade
- Ball Material - SUJ2 Equivalent
- Greased Filled - Not Provided

Example of Use

